

BAGS

Shown below are typical bags that can be produced on Absolut Manufacturing equipment.
Please contact an Absolut Sales Representative about your particular product size and design.

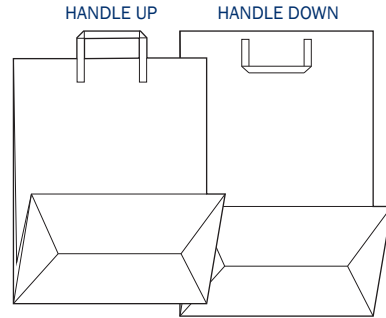

| GREEN ADVANTAGE | | FIXED 1/6 TH | FIXED 1/7 TH | DBM |
|-----------------|----|-------------------------|-------------------------|-----------------|
| FACE | IN | 11.875 or 12 | 11.875 or 12 | 11.875 or 12 |
| | MM | 301.6 or 304.8 | 301.6 or 304.8 | 301.6 or 304.8 |
| BOTTOM | IN | 6.875 or 7 | 6.875 or 7 | 6.875 or 7 |
| | MM | 174.6 or 177.8 | 174.6 or 177.8 | 174.6 or 177.8 |
| BAG LENGTH | IN | 17 | 14 | 17 and 14 |
| | MM | 431.8 | 355.6 | 431.8 and 355.6 |

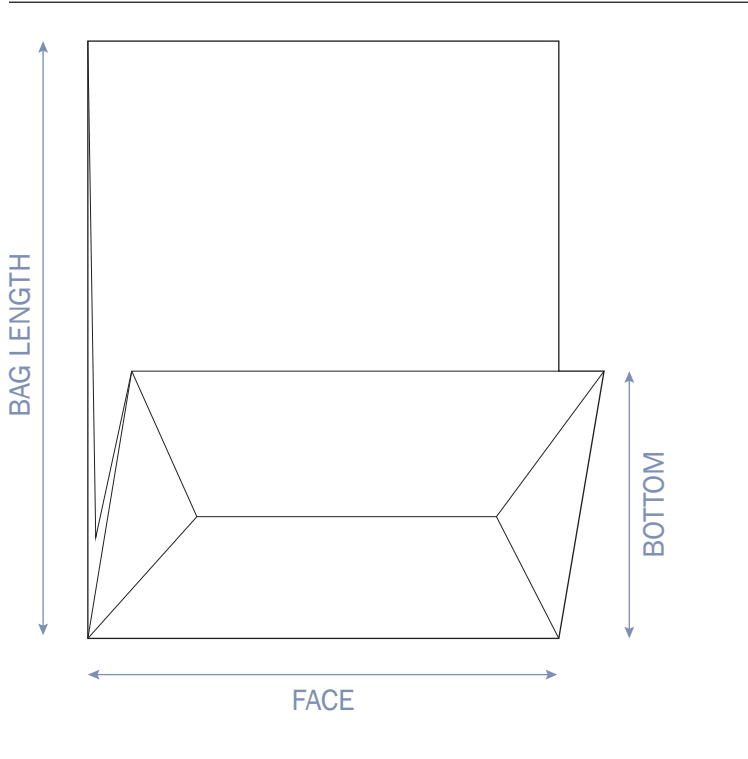
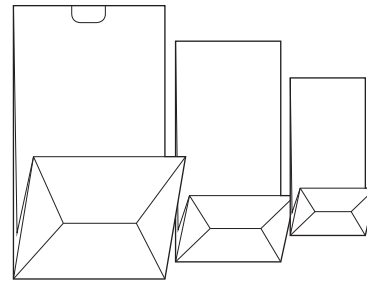

| VBM 300 (VARIABLE SIZE) | | |
|-------------------------|----|---------------|
| FACE | IN | 7 - 14 |
| | MM | 177.8 - 355.6 |
| BOTTOM | IN | 4 - 8 |
| | MM | 101.6 - 203.2 |
| BAG LENGTH | IN | 17 - 30 |
| | MM | 431.8 - 762 |

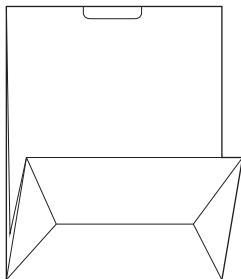

| QSR (FIXED SIZE) | | |
|------------------|----|----------------|
| FACE | IN | 4.125 - 11 |
| | MM | 104.8 - 279.4 |
| BOTTOM | IN | 2.5 - 6 |
| | MM | 63.5 - 152.4 |
| BAG LENGTH | IN | 7.906 - 13.75 |
| | MM | 200.8 - 349.25 |

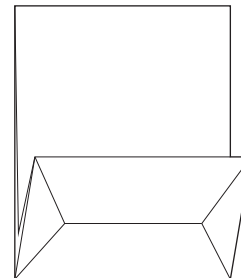

| CRS-150 (VARIABLE SIZE) | | |
|-------------------------|----|---------------|
| FACE | IN | 15 - 17 |
| | MM | 381 - 431.8 |
| BOTTOM | IN | 11 - 13 |
| | MM | 279.4 - 330.2 |
| BAG LENGTH | IN | 34 - 36 |
| | MM | 863.6 - 914.4 |



Absolut Manufacturing, LLC
68150 Front Street
Iron River WI 54847 USA
+1 715 372 8988
info@absolutmfg.com | www.absolutmfg.com

NONWOVENS

Shown below are typical nonwovens that can be produced on Absolut Manufacturing equipment. Please contact an Absolut Sales Representative about your particular product size and design.

ROADRUNNER CROSS-FOLDED WIPES

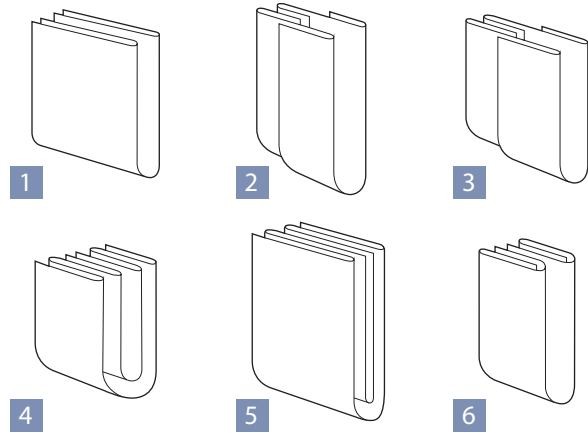

OTHER FOLDS AVAILABLE
CUTOFF RANGE 8" - 24"

CHEETAH INTERFOLDED WIPES

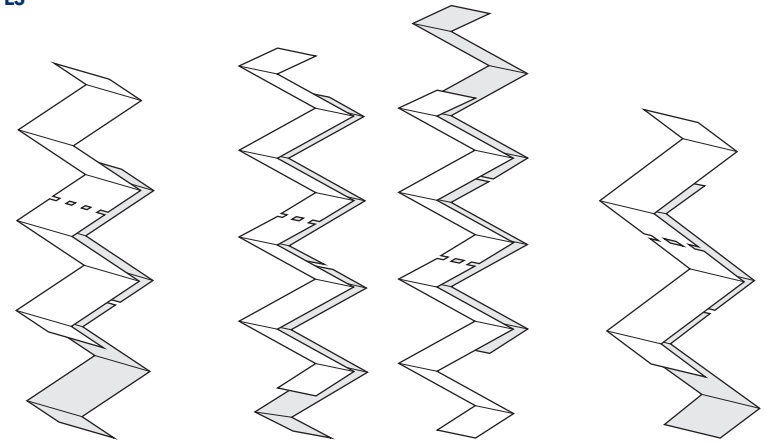

WiNDR CORELESS

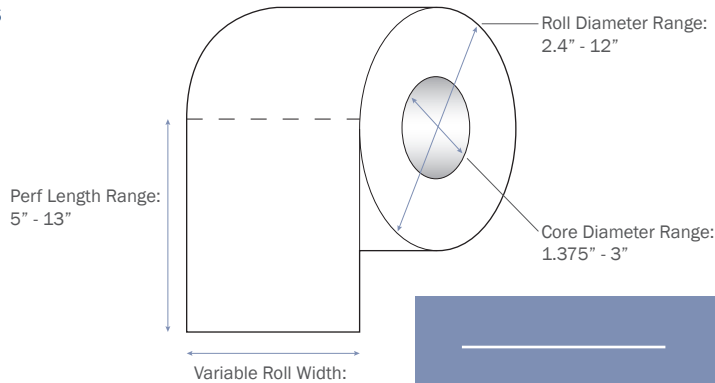

TORNADO CORED OR CORELESS

